



Careful sampling of a seed lot is an important step in obtaining a sample that accurately reflects the characteristics of the seed lot. Aside from carefully controlled production and conditioning practices, painstaking sampling is actually the first step in assuring accuracy and precision in seed testing.

The purpose of seed testing is to obtain information regarding the planting value of seed in any particular seed lot. For testing to be meaningful, seed samples must be properly collected. Seed tests often generate information that must, by law, appear on the seed label and/or is required for obtaining a phytosanitary certificate. Both the seed producer and the buyer rely on accurate laboratory information. Seed testing laboratories therefore must have modern equipment and well-trained analysts.

However, seed lot sampling may be beyond the control of the seed analyst conducting tests on the submitted sample. And if the submitted sample is not

representative of the seed lot, the laboratory analyses cannot accurately reflect the planting value of that seed.

The Seed Lot

A seed lot can be defined as a quantity of seed with every portion or every bag uniform within permitted tolerances as to percentage of pure seed, inert matter, other crop seed, germination and dormant seed, weed seed, and rate of occurrence of noxious weed seeds. A quantity of seed that is not uniform within permitted

tolerances should not be classified as a seed lot. Any variation should be reduced by further conditioning, by mixing, or by separating the quantity in question into two or more uniform lots.

The physical and/or physiological uniformity of a given amount of seed can be affected by a number of factors including: seed harvested from different fields or at different times; exposure of seed to different environments during production; damage done by frost (reduced seed quality in low-lying areas of a field (degraded seed quality); or moisture migration patterns and heating within a seed bin that has damaged certain portions of stored seed. Some plant species that have indeterminate growth habits produce seeds that are naturally variable in seed quality.

Sampling

Sampling of free-flowing seed is usually accomplished with various probes and triers (Fig. 1a & 1b). Short probes (Fig. 1a) are not recommended for sampling since they do not access all areas of the bag. Proper sampling of bagged seed is accomplished by probing the horizontal bag diagonally from corner to corner (Fig. 2). The trier should be long enough to sample along the entire diagonal distance of the bag. It should be inserted with slots closed and facing down. Upon full insertion into the bag, the slots should be rotated upwards to dislodge any seed that may have been carried along with the trier sections

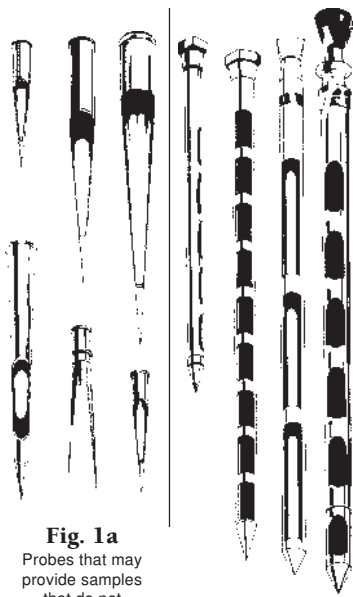

Fig. 1a
Probes that may provide samples that do not represent the lot.

Fig. 1b
Probes that may provide a representative sample.

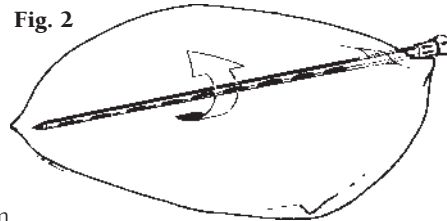

Fig. 2

Recommended method of probing bags of seed.

as the trier was inserted, and the slots opened.

Bags are usually sampled

according to the intensity recommended in the Association of Official Seed Analysts, "Rules for Testing Seeds." These guidelines recommend that 5 bags, plus



Sponsored by the Extension Services of Iowa, Minnesota, Missouri, North Dakota, Ohio, and Wisconsin in cooperation with ES-USDA.

North Central Regional Extension Publication 403, July 1991
Electronic version March 2000

... and justice for all

The U.S. Department of Agriculture (USDA) prohibits discrimination in all its programs and activities on the basis of race, color, national origin, gender, religion, age, disability, political beliefs, sexual orientation, and marital or family status. (Not all prohibited bases apply to all programs.) Many materials can be made available in alternative formats for ADA clients. To file a complaint of discrimination, write USDA, Office of Civil Rights, Room 326-W, Whitten Building, 14th and Independence Avenue, SW, Washington, DC 20250-9410 or call 202-720-5964.

Table 1: Recommended sampling intensity for seed in bags.

| | | | |
|------------------|----|-------------------|----|
| 1 to 6 | * | 135 to 144 | 19 |
| 7 to 14 | 6 | 145 to 154 | 20 |
| 15 to 24 | 7 | 155 to 164 | 21 |
| 25 to 34 | 8 | 165 to 174 | 22 |
| 35 to 44 | 9 | 175 to 184 | 23 |
| 45 to 54 | 10 | 185 to 194 | 24 |
| 55 to 64 | 11 | 195 to 204 | 25 |
| 65 to 74 | 12 | 205 to 214 | 26 |
| 75 to 84 | 13 | 215 to 224 | 27 |
| 85 to 94 | 14 | 225 to 234 | 28 |
| 95 to 104 | 15 | 235 to 244 | 29 |
| 105 to 114 | 16 | 245 to 254 | 30 |
| 115 to 124 | 17 | 255 or more | 30 |
| 125 to 134 | 18 | | |

* For lots of 1 to 6 bags, sample each bag and take a total of at least 5 cores or handfuls.

10 percent of the remaining bags should be sampled (Table 1). A minimum of six bags should be sampled and it is usually not necessary to sample more than 30 bags. Larger seed lots destined for overseas markets may require more intensive sampling according to the International Seed Testing Association Rules.

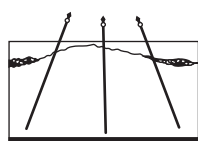
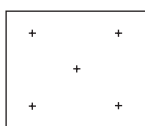

Fig. 3

Bulk Sampling



to time while the seed is flowing. Sampling intervals, as well as the quantity of seed taken with each sample, are usually adjustable. Automatic samplers may be “homemade” but are also available from a number of commercial sources. The commercial samplers are usually motor driven and can be installed in pipes, spouts, hoppers, chutes, and bagging bins. Automatic samplers that draw a sample from across the entire flow of the seed and close tightly following sampling most accurately sample the seed lot.

Most references indicate that when sampling seed in bulk, five to seven probes must be made. These probes (Fig. 3) should represent as many locations in the bulk as possible.

Non free-flowing seeds should be sampled by hand as follows; the hand is inserted into the bag with the fist open (Fig. 4). Upon reaching the appropriate location, the hand is closed (Fig. 4) and a sample taken. Every effort must be made to obtain samples from various locations in the bag.

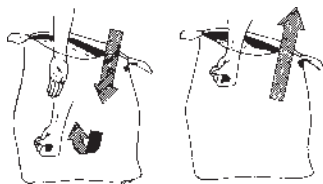

Fig. 4

Hand Sampling

Automatic Sampling

Automatic samplers are those placed in a conditioning line to take samples from time

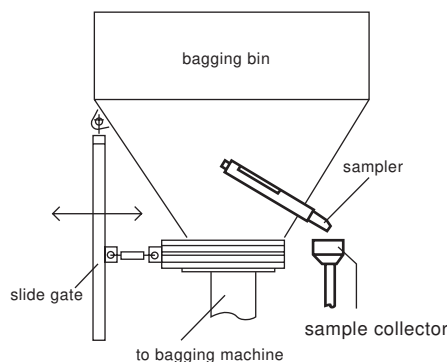

Fig. 5

Automatic sampler installed in bagging bin.

the sampler is placed in a hopper-bottom bagging bin. The sampler consists of two concentric tubes with open slots. When the tubes are rotated, matching up the slots, the seeds flow out. The volume of the flow can be controlled by a change in the area of slot presented to the seed flow.

Another automatic sampler installation point is in the bagging machine itself (Fig. 6). This sampler design is similar to the one just described. As each bag is filled, a few seeds dribble through the sampler and are collected in a container. This installation's advantage is that the sampler is more accessible for cleaning and adjustments between seed lots.

Regardless of the sampling protocol, all individual probes should be evaluated to determine whether or not there is any variation within the seed lot. If there is no apparent variation, the individual probes should be combined. The combined individual probes should be thoroughly mixed and a sample of the combined probes submitted to the Seed Testing Laboratory. Ideally, this sample should be obtained through the use of mechanical dividers to ensure that a truly random sample is collected from the mixture of the seeds that came from the individual probes.

For further information, refer to “Handbook for Seed Inspectors,” Association of American Seed Control Officials; and, Gregg, Bill, “A Good Seed Sample: the Real Picture of Seed Quality,” Circ. P-32, Coop. Ext. Serv., Auburn University—from which some of this discussion was derived.

Prepared by A.D. Knapp, and T.J. Gutormson, agronomists, and M.K. Misra, agricultural engineer, Iowa State University.

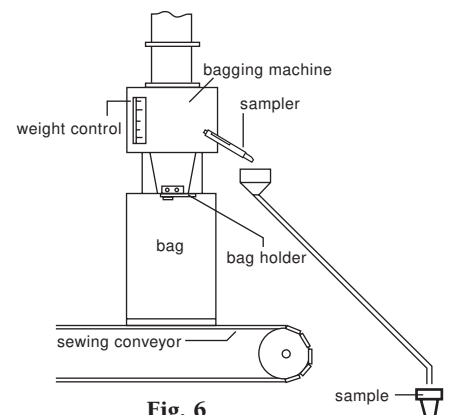

Fig. 6

Automatic sampler installed in bagging machine.